

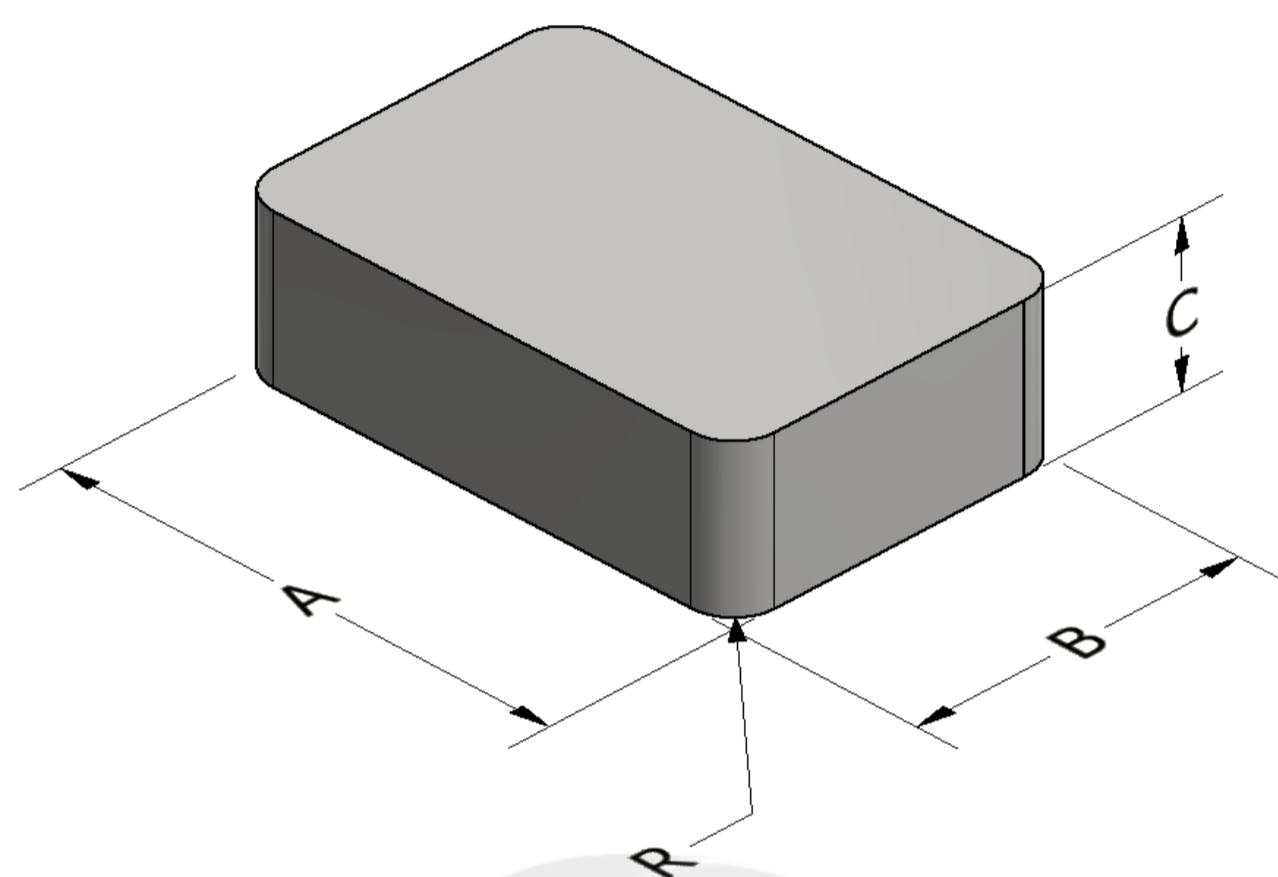

Part Number: **BMS-0474120-014**

Revision 20190529 - Generated 2019-May-29



| | | |
|----------------------------|--|-----------------------|
| A | 47.50 ± 0.50 mm | 1.870 ± 0.020 in |
| B | 41.00 ± 0.50 mm | 1.614 ± 0.020 in |
| C | 20.10 ± 0.50 mm | 0.791 ± 0.020 in |
| R | 1.5 ± 0.50 mm | 0.059 ± 0.020 in |
| | μ_i (reference) | 14 |
| Mass | (approximate) | 190 grams |
| Core Loss | $\text{Core Loss (mW/cm}^3\text{)} = \frac{f}{\frac{a}{Bpk^3} + \frac{b}{Bpk^{2.3}} + \frac{c}{Bpk^{1.65}}} + d \cdot Bpk^2 \cdot f^2$ | |
| | where B_{pk} expressed in gauss, f expressed in hertz, and: $a=1.00E+09$, $b=4.21E+08$, $c=1.03E+07$, $d=2.30E-14$ | |
| | B_{pk} | 300 G |
| | frequency | 100 kHz |
| | Core Loss (nominal) | 79 mW/cm ³ |
| Core Loss (maximum) | 90 mW/cm ³ | |
| DC Saturation | $\% \mu_i = \frac{1}{a + b \cdot H^c} + d$ | |
| | where H expressed in oersteds, and: $a=0.01$, $b=5.72E-08$, $c=2.00$, $d=0.00$ | |
| | H_{DC} | 200 Oe |
| | Percent Initial Perm(nom.) | 81.7% |
| Percent Initial Perm(min.) | 75.7% | |
| Coating/Pkg | Coating Type: | None |
| | Voltage Breakdown (min.) | N/A |
| | Limit | N/A |
| | Package Quantity | 60 Pieces/Box |

